

SDA SERIES SOLID STATE RELAY

**SDA-200C025I-1R
SDA-200C040I-1R
SDA-200C050I-1R
SDA-200C075I-1R
SDA-200C090I-1R
SDA-200C100I-1R**

DC Control AC Loading S.S.R

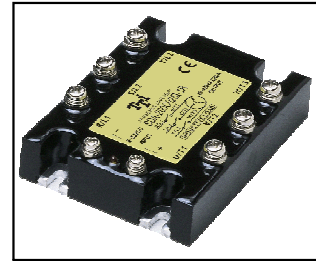

Specifications

MODEL SERIES NO.	CONTROL VOLTAGE	MUST TURN OFF VOLTAGE	INPUT IMPEDANCE	LOADING CURRENT	LOADING VOLTAGE	MIN BLOCKING VOLTAGE	MAX OFF-STATE LEAKAGE	FREQUENCY RANGE	MAX 1-CYCLE PEAK SURGE
SDA-200C025I-1R	6 - 32 VDC	MAX 3.0 VDC	1.5 KΩ	25A	24 ~ 280VAC	600VAC	LESS 10 mA	47-63HZ	315A
SDA-200C040I-1R	6 - 32 VDC	MAX 3.0 VDC	1.5 KΩ	40A	24 ~ 280VAC	600VAC	LESS 10 mA	47-63HZ	450A
SDA-200C050I-1R	6 - 32 VDC	MAX 3.0 VDC	1.5 KΩ	50A	24 ~ 280VAC	600VAC	LESS 10 mA	47-63HZ	560A
SDA-200C075I-1R	6 - 32 VDC	MAX 3.0 VDC	1.5 KΩ	75A	24 ~ 280VAC	600VAC	LESS 10 mA	47-63HZ	750A
SDA-200C090I-1R	6 - 32 VDC	MAX 3.0 VDC	1.5 KΩ	90A	24 ~ 280VAC	600VAC	LESS 10 mA	47-63HZ	900A
SDA-200C100I-1R	6 - 32 VDC	MAX 3.0 VDC	1.5 KΩ	100A	24 ~ 280VAC	600VAC	LESS 10 mA	47-63HZ	1030A

MODEL SERIES NO.	MAX OFF STATE dv/dt	MAX ON-STATE VOLTAGE DROP	ISOLATE IMPEDANCE	Dielectric STRENGTH INPUT-OUTPUT	Dielectric STRENGTH INPUT-OUTPUT-CASE	TURN ON TIME	TURN OFF TIME	CAPACITANCE IN-OUT	WEIGHT (g)
SDA-200C025I-1R	250 V/μ sec	1.6Vrms	10 ⁹ Ω	2500 VACrms	2500 VACrms	LESS ½ msec	LESS ½ AC CYCLE	LESS 473 PF	600 g
SDA-200C040I-1R	250 V/μ sec	1.6Vrms	10 ⁹ Ω	2500 VACrms	2500 VACrms	LESS ½ msec	LESS ½ AC CYCLE	LESS 473 PF	600 g
SDA-200C050I-1R	250 V/μ sec	1.6Vrms	10 ⁹ Ω	2500 VACrms	2500 VACrms	LESS ½ msec	LESS ½ AC CYCLE	LESS 473 PF	600 g
SDA-200C075I-1R	250 V/μ sec	1.6Vrms	10 ⁹ Ω	2500 VACrms	2500 VACrms	LESS ½ msec	LESS ½ AC CYCLE	LESS 473 PF	600 g
SDA-200C090I-1R	250 V/μ sec	1.6Vrms	10 ⁹ Ω	2500 VACrms	2500 VACrms	LESS ½ msec	LESS ½ AC CYCLE	LESS 473 PF	600 g
SDA-200C100I-1R	250 V/μ sec	1.6Vrms	10 ⁹ Ω	2500 VACrms	2500 VACrms	LESS ½ msec	LESS ½ AC CYCLE	LESS 473 PF	600 g

PARTS NO.

SDA-200C025I-1R

Switching Type : R = Random Switching
 Packing : 1 = Screw Type
 Phase : I = Inductive Load
 Loading Current : 025 = 25A, 040 = 40A, 050 = 50A, 075 = 75A, 090 = 90A, 100 = 100A
 Control Voltage : C = 6-32VDC
 Loading Voltage : 200 = 24~280VAC
 Control Type : DA = DC Control AC
 S = S.S.R

Outline Dimensions(Unit : mm)

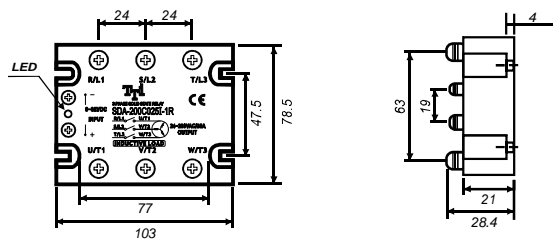

Equivalent Circuit

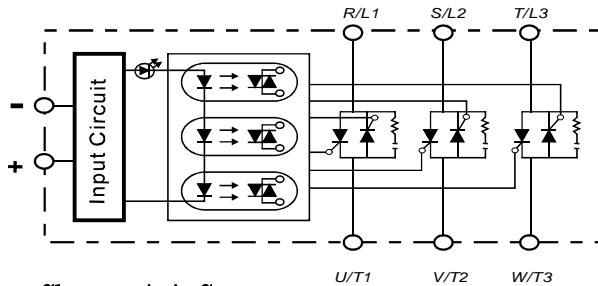

Example : 3φ S.S.R Application

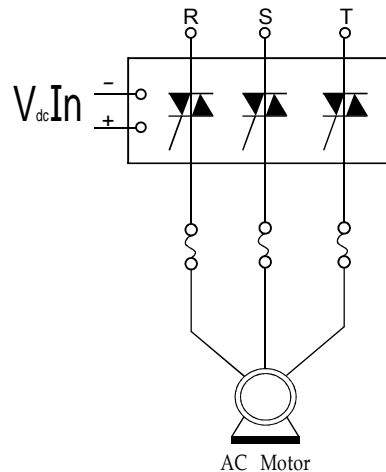

Characteristic Curves

RMS On-state Current Versus Case Temperature

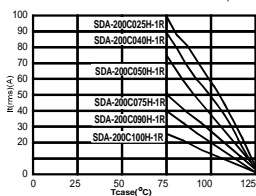

Non Repetitive Surge On-state Current Versus Number Of Cycles

